



Intelligent And Efficient Electronic Control System





ELECTRIC CONTROL SYSTEM PACKAGE

The system include gen control system, power management system, power distribution system, transformers, electric propulsion control system, vessel management system, etc.

- Gen control system include: Generator Control module, Speed control module, AVR module, electrical instrument, start/stop & speed/voltage adjust control panel, differential protector, income ACB, etc.
- Power distribution system include: Medium voltage SWBD, 690V/400V/230V Low voltage SWBD & Emergency SWBD, power transformers, power distribution box, shore power panel, etc.



(Gen Control System)



(SWBD&MCC)

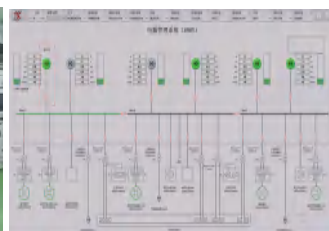

(PMS HMI)



(Power Transformers)

- Electric propulsion control system contains: rectifier transformer, VFD, control cabinet, local control panel, remote control panel.



(Electric propulsion driver and control system)



(Remote control panel)

- Vessel management system(VMS) contains: E/R monitoring and alarm system, valve remote control and level gauging system, extended alarm system, personnel safety system, wheelhouse / engine room control console.

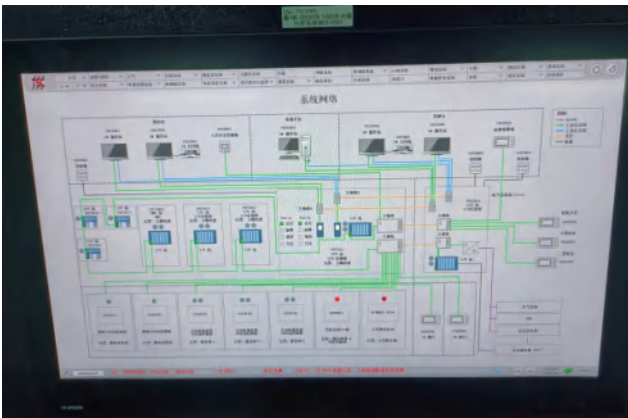

(VMS HMI)



(Wheelhouse Control Console-Front)



(Wheelhouse Control Console-Rear)



(Engine Room Control Console)

GEN CONTROL SYSTEM

The gen control system use a digital control scheme, which is suitable for various types and generators. The system includes multiple functional modules such as engine speed control, generator excitation control, manual and automatic start/stop, sync control, load share, electrical parameter monitoring, protection and display, and is the foundation of the ship's power management system.



(Gen Control System)

System Functions: << <

- Local/Remote start & stop the generator.
- Local/Remote sync control, gen online/offline.
- Gen voltage & frequency adjust.
- Gen soft loading and unloading.
- Automatic active and reactive power balancing.
- Gen over/under voltage, over/under frequency, overload, reverse power and differential protection etc.

POWER MANAGEMENT SYSTEM

The power management system(PMS) is based on the digital gen control system, applying PLC, industrial network, and human-machine interface technology to optimize the control of offshore platforms/ship power station, and to control and monitor the power distribution system.

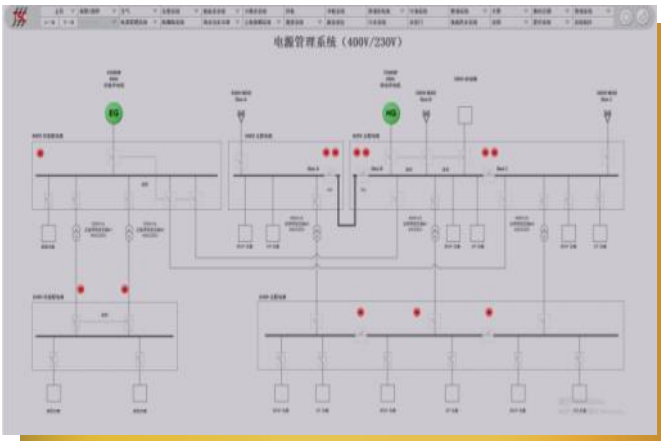

(PMS HMI)

Main Function: << <

- Engine parameter monitoring: air exhaust temperature, cylinder liner water temperature etc.
- Generator parameter monitoring: bearing & winding temperature etc.
- Electric parameter display: gen state, voltage, frequency, power etc.
- Generator start order setting.
- Load depending.
- Heavy load request control.
- Power limit control.

POWER DISTRIBUTION SYSTEM

SWBD, transformers, power distribution box, Electric Test Panel, shore power panel, battery charging and discharging boards, etc.

SWITCHBOARD

Typical Configuration: > >>

- Main gen control panel.
- 690V Bustie and Gen Synchronizing panel
- 690V SWBD
- 400V Main SWBD&MCC
- 400V Bustie panel
- 400V Emergency SWBD&MCC
- 230V Main SWBD
- 230V Emergency SWBD

Note 1: The actual voltage according the ship electric system.

Note 2: The SWBD & MCC type is design according to requirements.



(Gen Control Panel)



(MCC panel)



(SWBD panel)



(SWBD Room)

TRANSFORMER

Typical Parameter:

Transformer type: dry type;
 Winding material: copper/aluminum;
 Cooling type: AN/AF/water-cooling;
 IP Degree: IP23/IP44;
 Voltage&capacity: on-demand
 Connection group:on-demand

- Main Transformer(690V/400V)
- Lighting Transformer(400V/230V)
- Emergency Transformer(400V/230V)
- Galley/Laundry Transformer(400V/400V)
- Galley/Laundry Transformer(400V/230V)



POWER DISTRIBUTION BOX



Typical Parameter:

Voltage Degree:
 Power: 480V/400V,3P,50/60Hz;
 Lighting: 230V/120V,3p,50/60Hz;
 Loop numbers & CB breaking capacity: on-demand;
 IP Degree: IP44/ on-demand;
 Cable Entry Position:Bottom(default);
 Cable incoming mode: gland/MCT;

SHORE POWER PANEL



Typical Parameter:

Power Degree:
 690V/480V/400V,3P,50/60Hz;
 Rated Current and CB breaking capacity: on-demand;
 Shell material: carbon steel/stainless steel;
 IP Degree: IP44/IP56;
 Cable Entry Position: Bottom(default);
 Cable incoming mode: gland/MCT;

Configuration and Function;
 Incoming breaker
 Power indicator
 Power parameter display(Voltage,current,phase sequence,kWh);
 Phase sequence detect and auto change;

ELECTRIC TEST PANEL

The electric test panel is used for checking fuses, indicator lights, incandescent lights, fluorescent lights, and other electrical components on board.

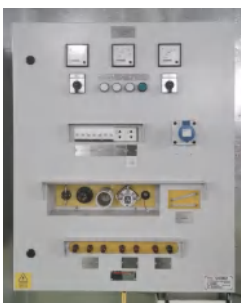

Typical Configuration:

Power Income:
 AC380V,3P,50/60Hz;
 Test terminal: AC380V,3P;
 Test terminal: AC230V,2P;
 Test terminal: DC24V,L-M;

CHARGE AND DISCHARGE BOARD



Typical Parameter:

Power incoming: main&emergency
 Incoming voltage: 400v,3p,50hz/ on-demand;
 Charge voltage & current: on-demand;
 Charge mode: constant voltage,constant current,floating;
 Charge type: auto change;
 Loop numbers and CB breaking capacity: on-demand
 Shell material: carbon steel with patting;
 IP degree: IP44/IP23;
 Cable incoming mode: cable gland;
 Installation type: wall mounted or floor mounted;

ELECTRIC PROPULSION CONTROL SYSTEM

TSC-HHCT can provide a packaged electric control solution for propulsion systems. Typically, the ship's main and bow propulsion electronic control systems include rectifier transformers, VFD, remote control system, propulsion motors, etc.

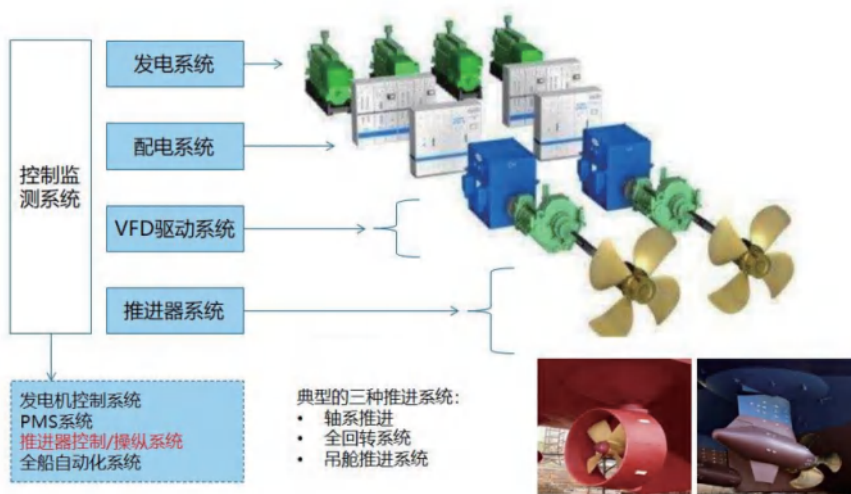

(Electric Propulsion System)



(Type Approval Certificate)

Typical Configuration(1600T wind power installation platform)

- 3 sets of azimuth thrusters(Motor: 660V,3000KW);
- 2 sets of bow thrusters(Motor: 660V,2200KW);
- Remote control panel of azimuth thrusters(wheelhouse-front&rear control console, engine room control console, local control panel);
- Remote control panel of bow thrusters (wheelhouse-front&rear control console, local control panel);



(Main Thrusters VFD and Control Cabinet)



(Remote Control Pane)

MARINE HYBRID POWER SYSTEM

HHCT, CM Energy's subsidiary can provide a complete integrated packaging solution for marine hybrid power systems including related products:

- Diesel generator set control system and distribution board;
- Power Management System (PMS);
- Isolation transformers and frequency conversion devices (corresponding to shaft generators, energy storage batteries, bow thrusters, etc.);
- Shaft generator system: including shaft generator control systems, shaft-driven generators, etc., with various operating modes (PTI/PTO/PTH);
- Energy storage system: including Energy Management System (EMS), energy storage battery packs (including Battery Management System (BMS)), with capacities configurable according to customer requirements;
- Bow thruster drive system: including drive motors, remote control devices, etc.;

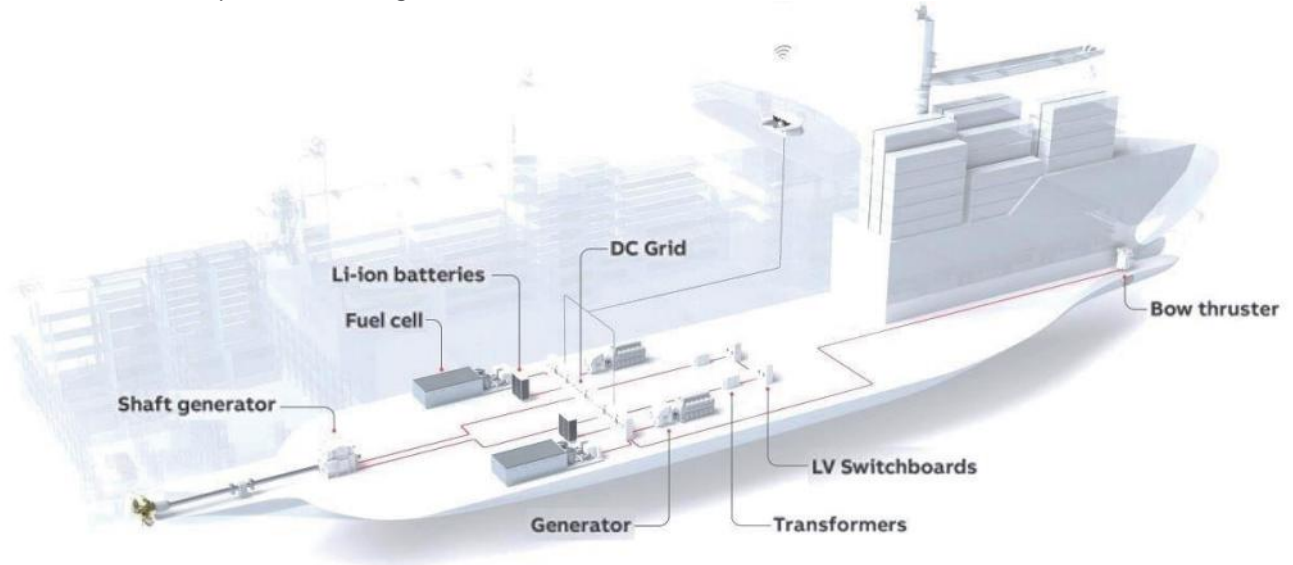

Typical Hybrid Power System Products
(using aRo-Ro ship as an example)

System Configuration

Permanent Magnet Synchronous Shaft Generator Variable Frequency

System, including:
Grid-side rectifier (PTI/PTO);
Shaft generator inverter;
Bow thruster inverter;
Energy storage system DC/DC converter;
Variable frequency water-cooled unit;

Isolation transformer

Energy Storage System (including BMS)

PMS Control System

EMS Control System

IAS Control System

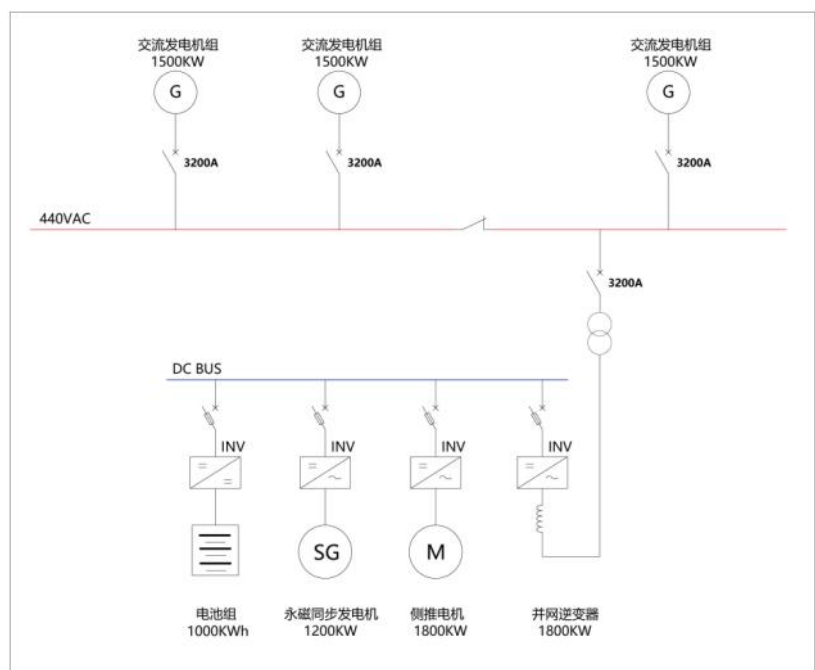

典型系统单线图

Hybrid Control System Composition and Functions:

PMS:Used for controlling and monitoring various power stations, with functions including:

- Control and monitoring of start-stop for diesel generator sets/shaft drive systems/energy storage systems
- Display of power supply parameters, such as operating status, generator voltage, frequency, power, etc;
- Load balancing and load distribution control, power limitation;
- Heavy load inquiry, priority tripping control for non-essential loads;

EMS:Energy Management System is used for controlling and monitoring energy storage devices and their drives, with functions including:

- Work mode selection;
- Control of energy flow in the energy storage system;
- Grid-connected/island operation;
- System operation monitoring and protection;

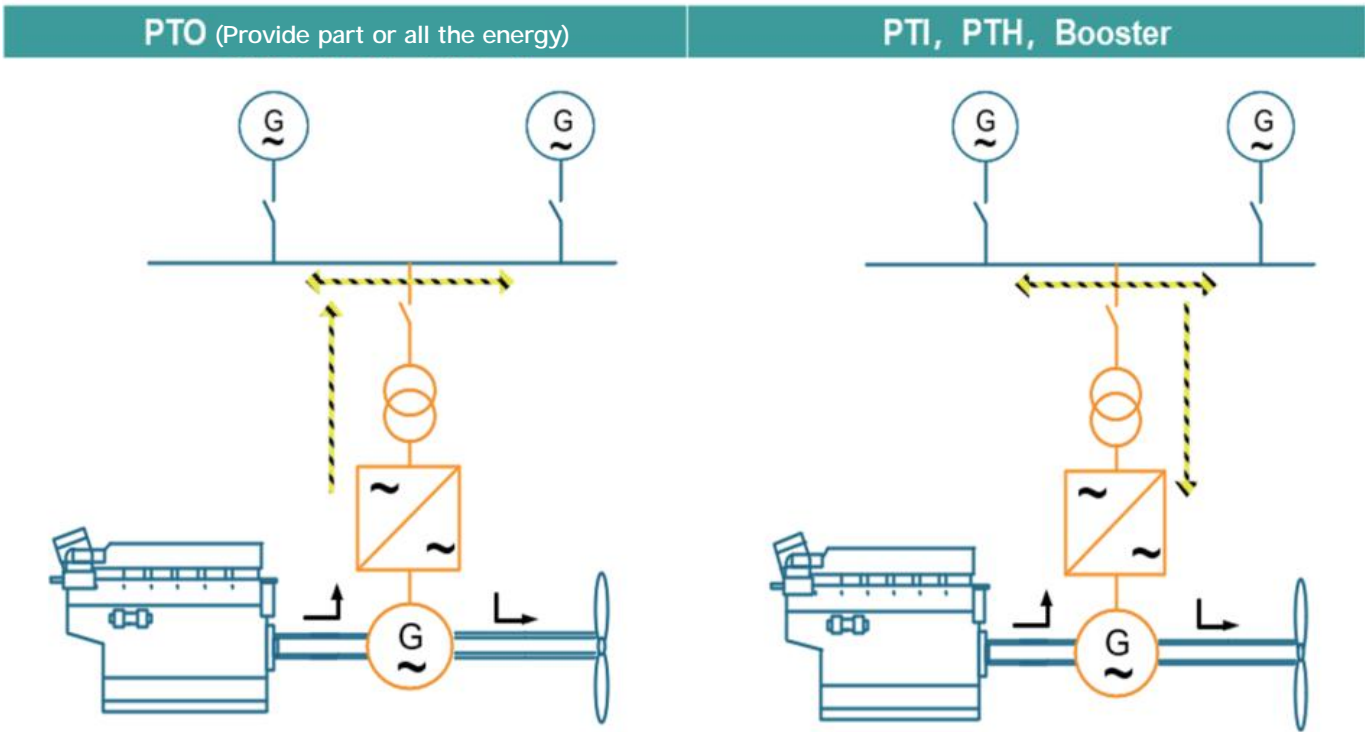

Hybrid Control System Product Photo:



PMS+EMS Control Cabinet



Control System HMI

VESSEL MANAGEMENT SYSTEM

The vessel management system(VMS) is a comprehensive alarm monitoring and management system developed based on the communication and PLC distributed control. The system contains: E/R monitoring and alarm system, PMS, valve remote control and level gauging system, extended alarm system, personnel safety system, wheelhouse / engine room control console, etc.

Typical System Configuration(1600T wind power installation platform)

- Redundancy PLC and MRP network, 4 PLC cabinets,1 PMS cabinet, 3 I/O box connect to redundancy MRP network by cable.
- 5 IPC connect to A/B dual network. Single network failure does not effect the continued operation.
- 6 extend alarm panel,1 personnel safety system connect to Redundancy MRP network by switcher;
- Communication with the valve remote control system, the VMS HMI integrates valve remote operation and status display;
- I/O configuration: about 2000 hardware points, 5000 software points;



(Personnel Safety System Panel)



(Extended alarm Panel)



(Control Console-HMI)

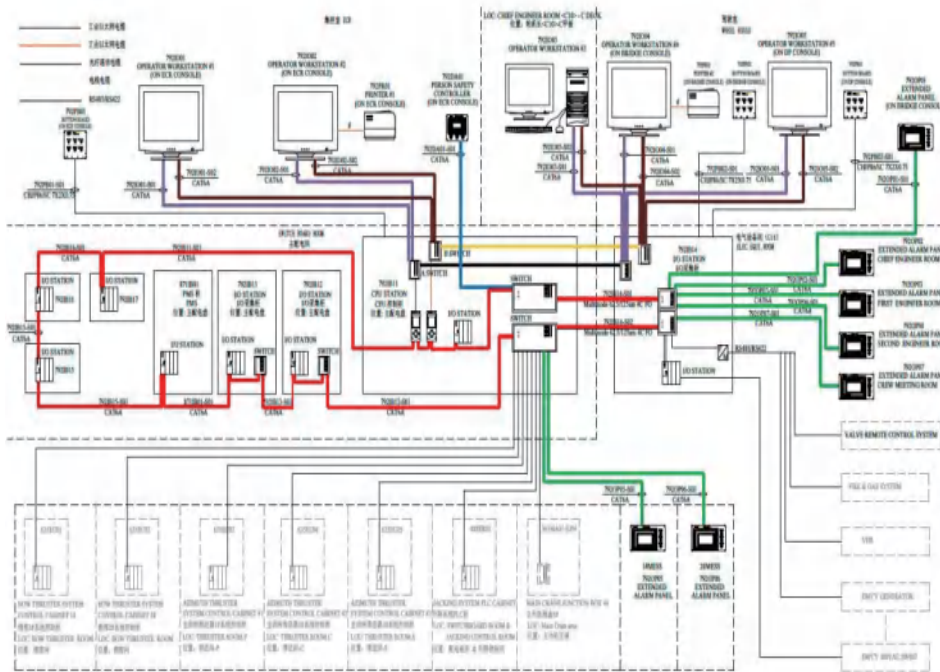

(System Network Diagram)



(Certificate of type approval)

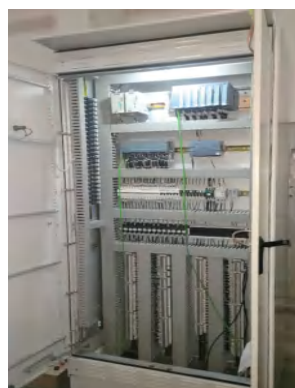

(PLC Control Cabinet)

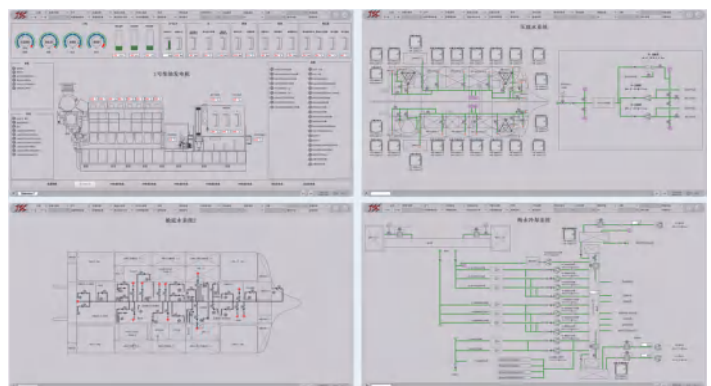

(HMI)

JACKING CONTROL SYSTEM

OFFSHORE PLATFORM JACKING CONTROL SYSTEM

TSC jacking control system products have been widely used in offshore self-elevating drilling platforms, wind turbine installation platforms, liftboats, etc. The full series of jacking control systems are as follows:

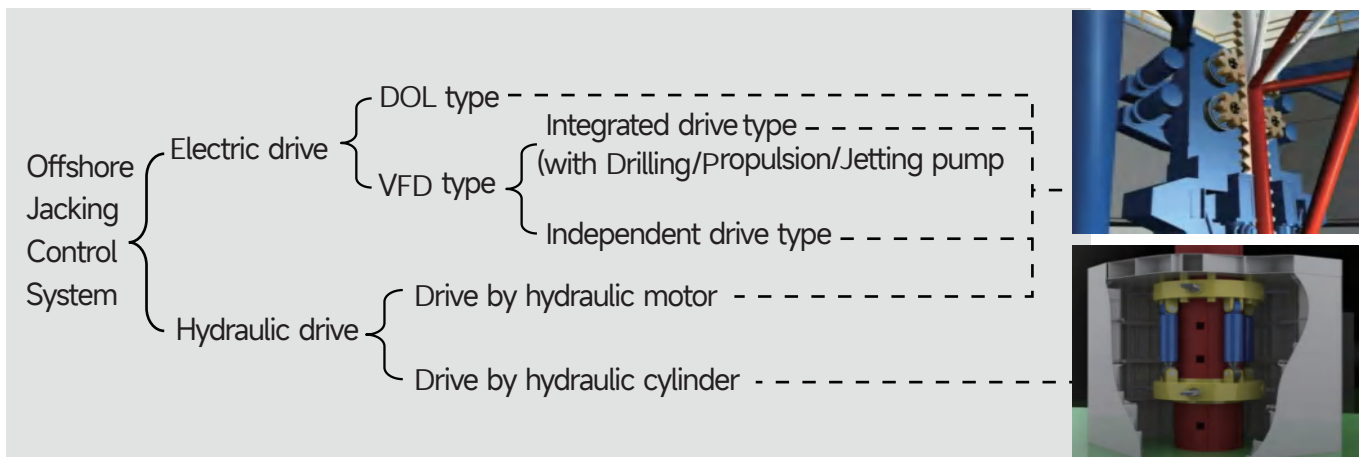

The jacking control system uses industrial computers and PLC controllers as the core controllers. Through script and logic programming, it completes the logic control, data calculation, safety protection, parameter setting, status monitoring, data recording, alarm, trend, fault diagnosis and other functions.

System Configuration: > >>

Typical VFD/Hydraulic Jacking System consist:

- VFD/Hydraulic power unit(HPU)
- Jacking MCC
- PLC system
- Leg height measurement device
- Central Control Console
- Local Control Console
- Electronic inclinometer



(Central Control Console)

Operation and Control Description: > >>

The jacking control system is a highly secure and reliable system, there are hundreds of safety interlocks related to the coordination between platform status and control systems, braking and driving system, and nearly a thousand alarm protections. The jacking and driving systems have passed FMEA analysis and have been certified by the classification society.

Control Function Description: > >>

- 1) CCC control mode
 - Speed 1:hull jacking speed(range: 40%-100%)
 - Speed 2:Leg jacking speed(range: 40%-110%)
 - Retorque control
 - Leg RPD detection and protection
 - Single/All legs jacking down or up operation
 - Motor overload and control logic protection
 - HMI-Monitoring jacking system status
- 2) LCC Control mode
 - LCC Control mode selection confirmation
 - Brake test
 - Single chord/Leg adjust
 - Load transfer(Suitable for use with locking devices)

Jacking Monitoring system: > >>

Jacking control system used touchscreen for HMI, suitable for monitoring and jacking operation, the typical functions are as follows:

- Leg height and jacking status display
- Jacking unit motors&brake status display
- Hull inclination status display, inclination alarm/stop value setting
- Load-Leg's total,average,Maximum,Minimum
- Leg's height calibration,setting alarm value for the up/down
- Leg's speed setting
- Motor load monitoring
- Retorque control
- Pins status(Hydraulic jacking system)
- Valves status(Hydraulic jacking system)
- Jacking control system bypass control
- Jacking control system parameter setting
- System trend record,archive
- System network diagnose
- Sytem control diagnose



(Jacking System HMI-VFD)

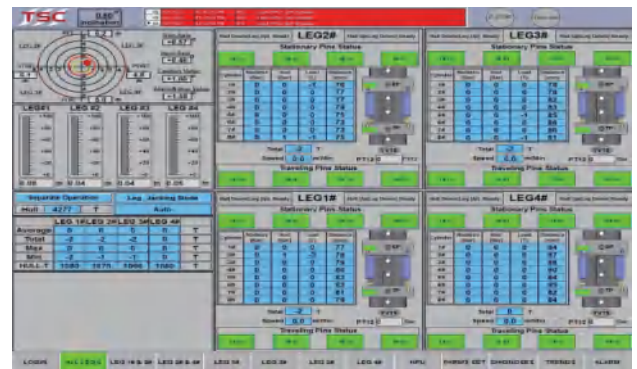

(Hydraulic Jacking System HMI)



(Diagnosis HMI)

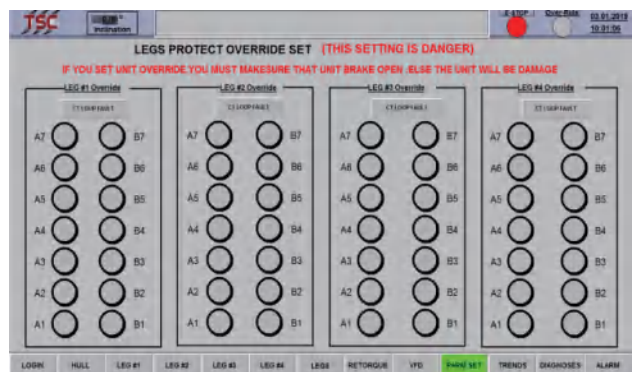

(Bypass HMI)

SEAWATER TOWER ELECTRIC CONTROL SYSTEM

The electric control system of the seawater tower works with the submersible pump, the main function is to adjust the inlet depth of the seawater pump to ensure the normal operation of the pump.

System Configuration: > >>

- Seawater Tower local control console
- Seawater pump control cabinet
- Local sensors
- Remote control interface (displayed separately or integrated into the jacking system HMI)

Main Functions: > >>

- Seawater tower local/remote up&down control
- Jacking motor single control, for the tower levelling
- Display seawater pump depth, current, height, etc.
- Seawater pump depth auto adjust (work with jacking system)
- Seawater pump local/remote-start/stop control
- Seawater pump overload, overheating, short, shallow protection

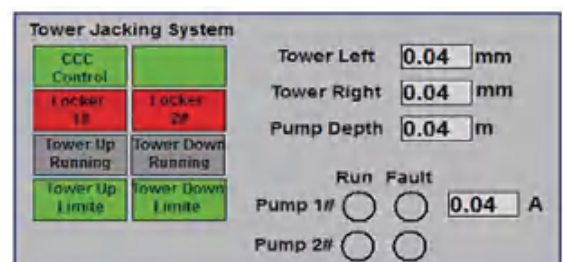



CRANE CONTROL SYSTEM

OFFSHORE CRANE CONTROL SYSTEM

The Crane control system is driven by VFD system, its suitable for various types of cranes (large, medium, and small) on offshore engineering platforms and drilling platforms.

Typical Configuration for VFD driven crane:

- Rectifier transformers
- VFD system
- Brake resistor
- Control power cabinet
- PLC Control System
- Crane Control Console & HMI
- Crane electric control room

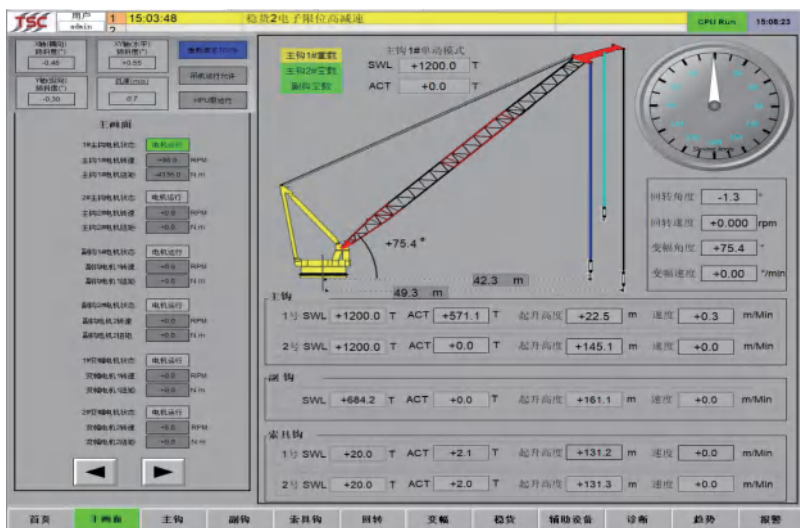

(Crane Control System HMI-Main Picture)

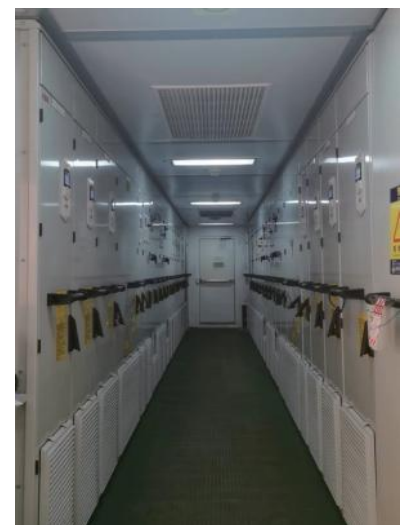

(Crane Electric Control Room)

Main Configurations and Functions: > >>

Drive Part:

- The driving part use the multidrive VFD system, which drives the main hook, auxiliary hook, luffing, slewing, rigging and other main motors of the crane.
- The main drive's module has redundancy function, and the slewing motor loop has bypass function.

Control Part:

- The control system mainly uses PLC, and the system network is constructed using industrial Ethernet.
- The system is equipped with overload protection devices, position encoders, boom angle sensors, drum overspeed switches, anemometers, inclination meters, and other monitoring devices to achieve comprehensive load, position, environmental monitoring and protection functions.
- Parameter settings with graded protection, such as alarm limit values for main equipment speed, hook load, slewing speed, slewing angle, boom elevation angle, etc;
- Bypass functions, such as slewing motor bypass, strong wind bypass, limit bypass, etc;
- The system fault diagnosis and operation diagnosis functions for quick troubleshooting.

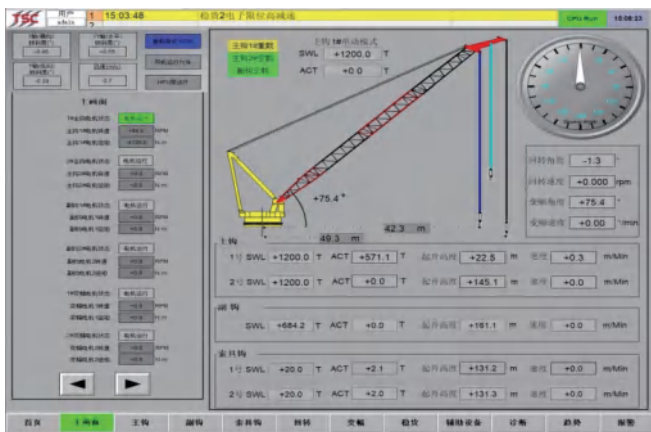

(Crane Control System HMI-Main Picture)

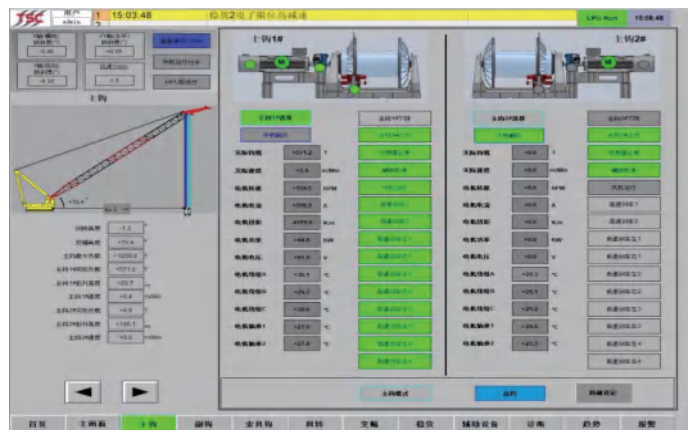

(HMI-Main Hoist)



(HMI-Diagnose)



(Crane Operation Chair&HMI)

PORTAL CRANE CONTROL SYSTEM

The control system of a gantry crane consists of drives, control systems, sensors, machine accessories, and other components.

Configurations and functions: > >>

Drive part:

- The driving part use the independent VFD device to drive the crane operation-walking, slewing, luffing, and hook lifting.

Control part:

- PLC is the core of the control system, and the network is built by Profinet/Profibus communication.
- The driver's cab is equipped with a control console, crane HMI, monitoring display, fire alarm device, weight display, wind speed alarm display device, etc.
- The HMI use touch screen, and the system is equipped with a IPC server, Its built-in equipment and network fault diagnosis, operation process diagnosis functions.
- The system has emergency bypass functions, such as strong wind bypass, limit bypass, etc.



OFFSHORE DRILLING PACKAGE EQUIPMENT



INTEGRATED DIGITAL DRILLER'S CABIN

The integrated digital driller's cabin is equipped with an electronic driller's chair, which can control and monitor the drawworks, mud pumps, rotary table, top drive, iron roughneck, catwalk, tubular & riser handling equipment, BOP, manifold and other equipment. It meets the technical requirements of drilling technology in different working conditions, such as drilling, tripping and pipe arranging, and provides highly centralized control operation and monitoring for the driller.

Typical configuration of driller's cabin: > >>

- Positive pressure explosion-proof stainless steel house body
- HVAC system
- Main driller's chair (pipe arranging/drilling control, switchable)
- Assistant Driller's seat (pipe arranging/drilling control, switchable)
- BOP& DIV control box
- Chock & kill control box
- CCTV system
- TALKBACK system
- PAGA system
- VMS monitoring station
- ESD control panel
- F&G control panel
- Automatic explosion-proof wiper device
- Normal lighting & Emergency Lighting

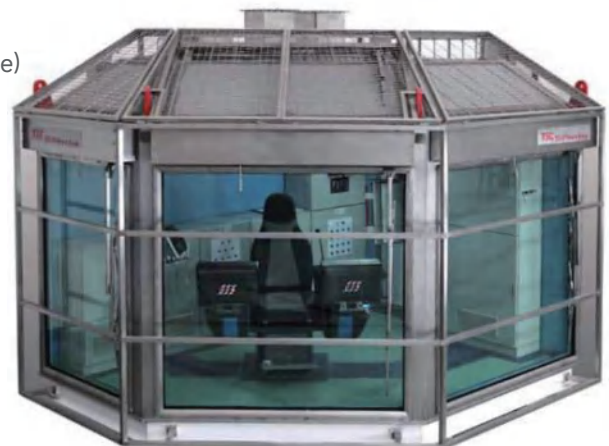

(Single Driller's Chair Driller's Cabin)

Driller's cabin characteristics: > >>

- Integrated design, integrating multiple device controls, and reserving installation/control interfaces for third-party devices, such as BOP operation panels, PAGA panels, VMS panels, etc.
- Customized according to user requirements, such as double driller chair.
- The structural design meets the requirements of integrated control of machinery, electricity, hydraulic and air, and also meets the special requirements of explosion-proof, anti-corrosion, moisture-proof, sound insulation and fire prevention in land/offshore drilling.
- Configure HVAC system to control indoor temperature and maintain positive pressure.
- The observation window is made of large-area and high-strength fireproof insulating glass, which has a wide operating field of vision. The reasonable layout of driller's cabin meets the reliability and comfort of operation.
- The primary observation windows are equipped with explosion-proof wiper systems



(Driller's Cabin - Double Driller Chair)

ELECTRONIC DRILLER OPERATION STATION

The electronic driller operation station is the operation center of the drilling control system and automated piping equipment, integrating the control and monitoring of drawworks, mud pumps, rotary table, top drive, iron rough-neck, catwalk machines, and other equipment, meeting the requirements of different working conditions and processes, and achieving centralized operation and monitoring of drilling related equipment.

Configuration and Function: > >>

- Keyboard +HMI soft keyboard (redundant configuration)
- HMI touch screen (redundant configuration)
- Multifunctional joystick
- System emergency stop operation and external interface
- Integrate CCTV and TALKBACK.
- Third-party operating equipment installation interface
- The adjusted seat (manually/electrically), with the back-and-forth translation of 200mm and lifting of 45mm, the backrest adjustment range of 60~150 degrees;
- Leather seat, comfortable and breathable.



LOCAL INSTRUMENT / ELECTRICAL ROOM

The local instrument/electrical room in drilling package is the customized skid-mounted electric control room, which is used to integrate driving/control cabinets of rig floor equipment related to the drilling control system.

The typical configuration is as follows:

Internal Equipment:

- MCC of drill floor
- Normal lighting panel of drill floor
- HPU soft start control cabinet
- Drilling control PLC
- Drilling instrument PLC
- Zone management system control cabinet
- Top drive control cabinet
- Iron roughneck control cabinet
- Pipe racking system control cabinet
- CCTV control cabinet
- Integrated power cabinet
- F&G detection probe
- PAGA equipment



External Equipment:

- Air conditioning unit + positive pressure ventilation system (as required)
- HVAC device (as required)



INTELLIGENT DRILLING CONTROL AND DIAGNOSIS SYSTEM

After years of application and optimization, we combine drilling control with VFD application, use industrial network, take IPC and PLC controller as the control core, and develop a set of stable, reliable and easy to maintain drilling control system through script and code programming. This system includes logic control, data processing, safety protection, parameter setting, state monitoring, data recording, alarms, trends and fault diagnosis of all drilling equipment. It has the characteristics of easy maintenance and high reliability. The typical system topology is as follows:

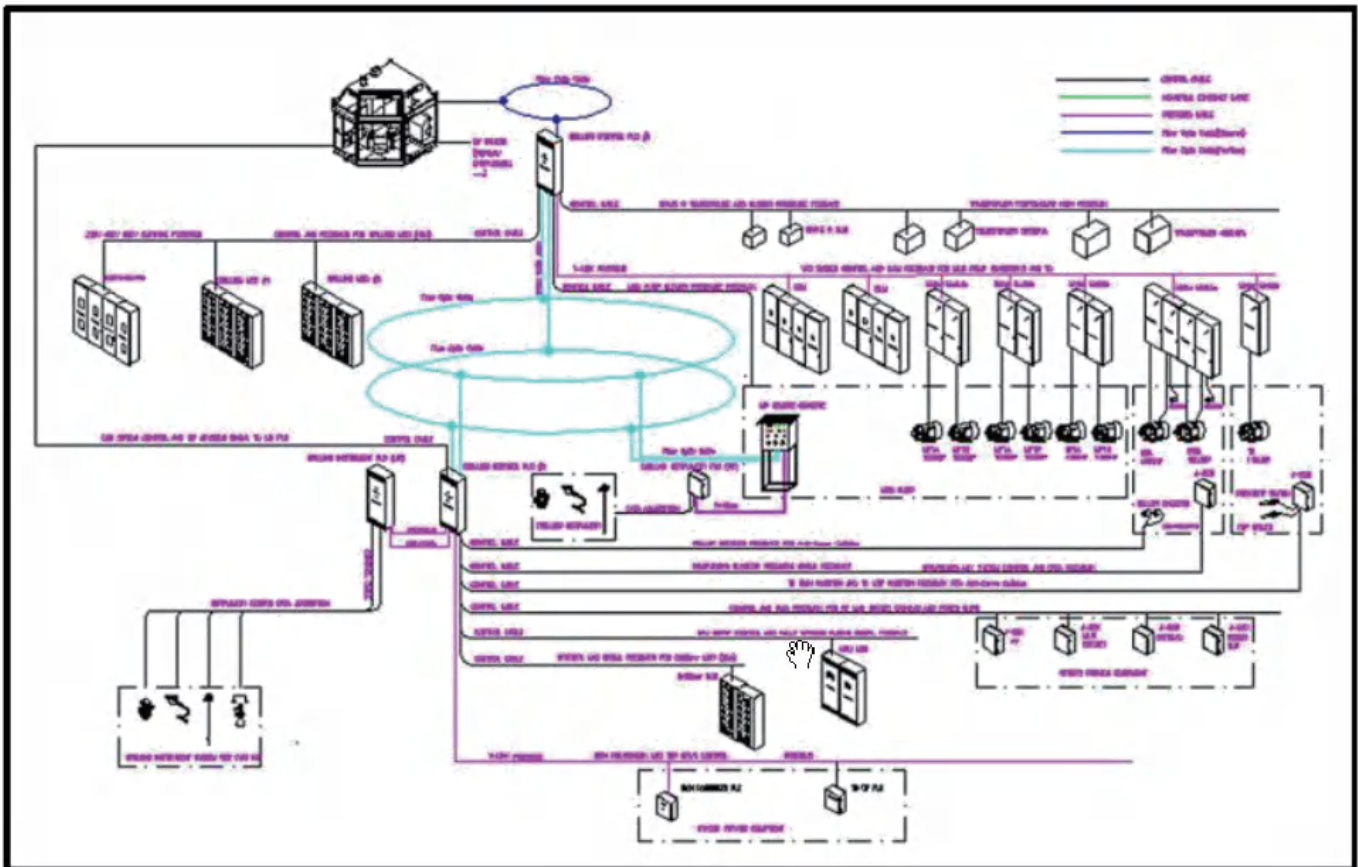

(System Topology Diagram)

System Configuration

- Driller Operation Station
- PLC system for drilling control
- Drilling control network
- IPC and components
- HMI
- Sensors and actuators
- CCTV system
- Talkback system

DW control system

- Control of drum speed and torque
- Auto drilling mode: WOB, ROP, constant pump pressure and constant torque.
- Calculation and display of traveling block position (diagrams and figures)
- Accurate management of static and dynamic parking position
- Control, monitoring and alarm of winch disc brake
- Control and monitoring of DW auxiliary equipment
- DW motor temperature monitoring and alarm
- State monitoring and protection of VFD, motor and hydraulic system

RT control system

- Forward and reverse rotation control
- RT speed and torque control
- Control and monitoring of RT auxiliary equipment
- Temperature monitoring and alarm of RT motor
- State monitoring and protection of RT motor or hydraulic system

TD control system

- Full-function hydraulic and electrical control
- Selection of TD control mode, drilling/Make-up and Break-out
- Speed and torque control of TD in different modes
- Link and elevator control
- Backup wench control
- IBOP control
- State monitoring and protection of VFD, motor and hydraulic system

Auxiliary mechanical control system

- Iron roughneck and mud box
- Power slip
- Pipe racking machine
- Mouse hole, catwalks and hydraulic cat heads

CCTV monitor

- Camera control, focal length adjustment, pan tilt control
- Monitoring screen control

Zone management (in system)

- Anti-collision of traveling block
- Safety control and interlock between equipment operation
- Override control
- Pre-alarm and alarm

Mud pump control system

- Main pressure adjust for stable well control
- Accurate control of pump stroke
- Soft pump function can make the pressure fluctuation of manifold stable, prolong the life of related components and reduce downhole accidents
- Control and monitoring of auxiliary equipment of mud pumps
- Temperature monitoring and alarm of mud pump motor
- Real-time and historical data recording and trends

Talkback system

- Intercom communication between main operating areas, such as driller's cabin, drilling floor, racking board, BOP area, mud pump room, etc.

Intelligent drilling instrument

- Data interaction with drilling instrument system
- Data display, calibration and alarm setting of drilling instruments
- Real-time and historical data records and trends of drilling instruments



(Drilling Control HMI-1)

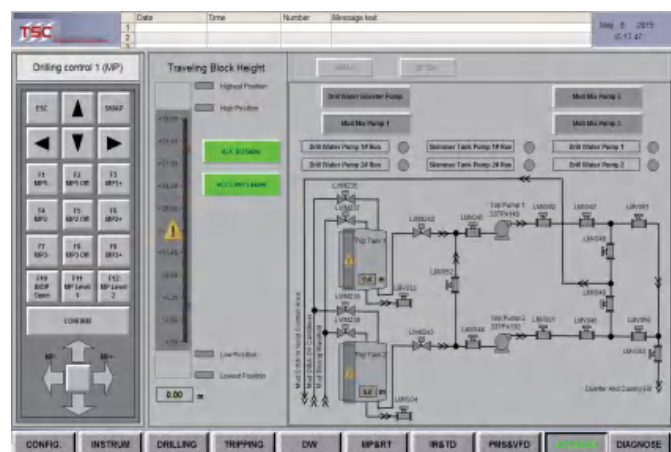

(Drilling Control HMI-2)

Diagnostic system

A specialized diagnostic system is designed within the drilling control system, through the analysis of control logic & control status, the system can be used to monitor the state of each control point of device in real time, and display on HMI. The diagnostic system can detect operating conditions and the cause of equipment failures, and provide alarm prompts, including system network node diagnosis.

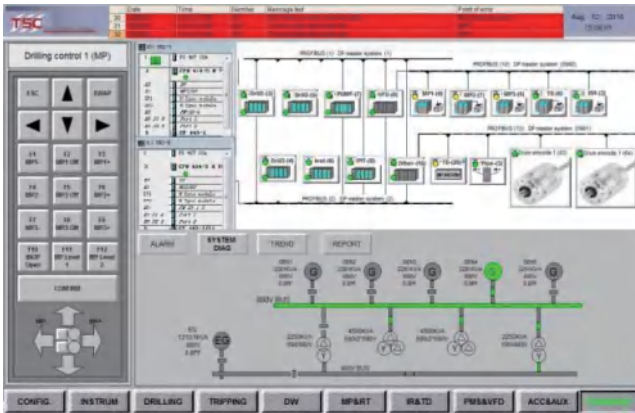

(Diagnostic system HMI-1)

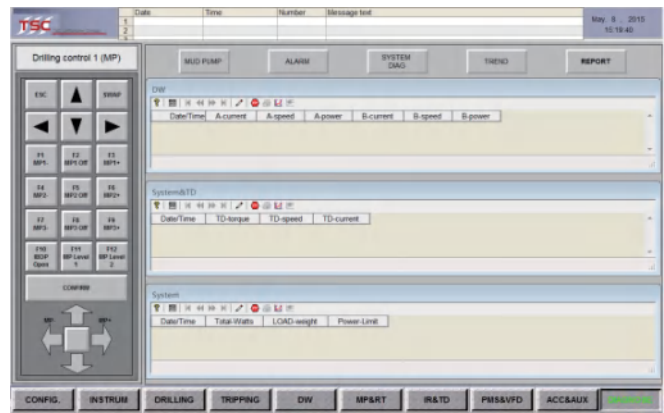

(Data report HMI-1)

INTELLIGENT DRILLING INSTRUMENT SYSTEM

The intelligent drilling instrument system is based on sensors, PLC controllers, and field bus. The system is equipped with multiple sensors to collect drilling site signals, and real-time monitoring of parameters such as speed, temperature, level, and flow in equipment/systems such as drilling drawworks, mud pumps, mud storage, and mud circulation, the system will generate multiple derived calculation parameters for construction personnel, and all instrument data will be integrated into the drilling system within the HMI interface, featuring integrated display and efficient operation. The main functions and display parameters are as follows:

- Graphical digital display of mud tank level, alarm setting
- Display and alarm of mud increment / decrement
- Mud inlet and outlet temperatures
- Calculation and display of mud density
- Pump stroke display
- Standpipe pressure
- Casing pressure
- Hook load
- Drilling depth
- Drilling speed
- Hook height
- Real-time and historical data records and trends
- Sensor calibration

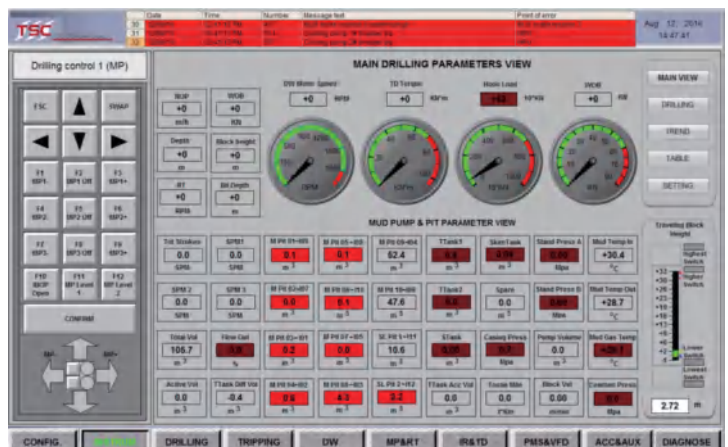

DRILLING ZONE MANAGEMENT SYSTEM

In the drilling system, each equipment operates on a certain path and trajectory. If it enters the same area at the same time, there is a risk of collision, resulting in equipment shutdown or damage, and even causing casualties. The drilling zone management system can effectively prevent the occurrence of such problems. The system will automatically identify potential collision points between various equipment within the drilling floor space, and reduce and avoid safety hazards through methods such as alarm, deceleration, or stop.

The main equipment in the drilling floor area includes: top drive, drawworks, iron roughneck, vertical pipe racking machine, pipe transfer crane, HTV, casing stabbing arm, mouse hole, etc.

The following figure lists the possible collision areas between devices.

System Configuration and Function: > >>

- Central processing unit of anti-collision control system
- Position detection sensor
- External hard wire interface-interlocking signal
- External communication interface-data acquisition
- Anti-collision control program and HMI, including automatic mode/manual bypass mode

Characteristic: > >>

- The detection sensor is connected to the PLC controller on each single device, and the PLC is connected to the anti-collision control unit through the Ethernet switch.
- The central processor of the anti-collision control unit receives the data from each position detection sensor, calculates and classifies it, and then sends an alarm or stop signal to the single equipment.
- The anti-collision modes for each single device can be set: operation mode or bypass mode.

When multiple equipment cross-operate, the system sends signal as alarm, slowing down, stopping, etc. to the equipment that will collide, which ensures the safety of equipment and personnel, reduces the labor intensity of workers, improves the work efficiency, and effectively prevents the potential danger of collision between single equipment in the drilling equipment area.

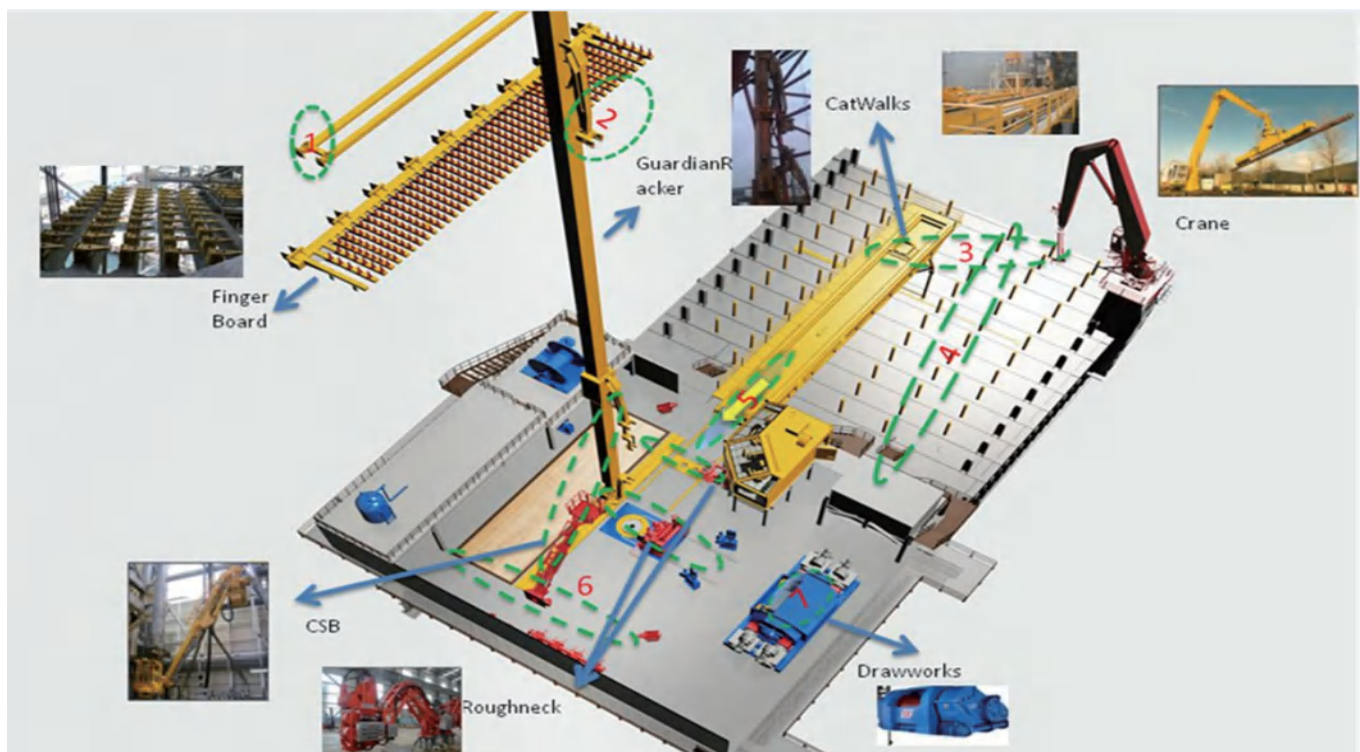

CANTILEVER BEAM SLIDING CONTROL SYSTEM

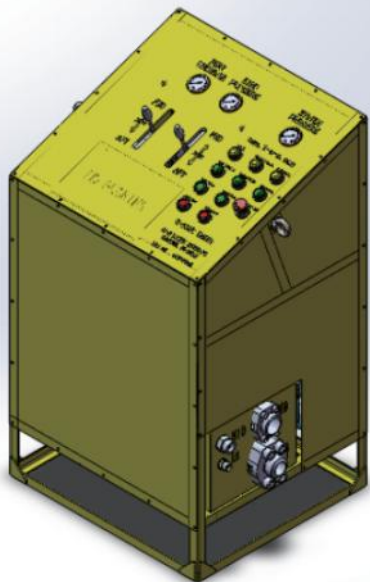

(Cantilever beam sliding control console)

After the jack-up drilling platform is in place, the cantilever beam of the drilling floor is slid to the drilling position through the cantilever beam sliding device.

The electric control system of cantilever beam sliding mainly includes the following equipment:

- Cantilever beam sliding console
- HPU local control cabinet
- HPU hydraulic station (including motor and oil tank)
- Field sensor

Main function: > >>

- Sliding operation of cantilever beam.
- HPU start/stop and emergency stop control, operation monitoring (oil temperature, oil pressure, etc.) and protection.
- HPU motor drive and protection.



ELECTRIC CONTROL SYSTEM OF LAND DRILLING RIG

The electric driving and control system is an important part of electric drilling rig. TSC-HHCT can provide various types and specifications of electric control products for drilling rigs. The specific product series and configuration are as follows:

Product Series

For 4000~9000m DC drilling rig: 40D, 50D, 70D, 80D and 90D

For 3000~9000m AC drilling rig: 30DB, 40DB, 50DB, 70DB and 90DB

For 5000~7000m chain-drive drilling rig: 50LDB, 70LDB

For 3000~9000m rig: the high-voltage power grid products 3500~5000KVA

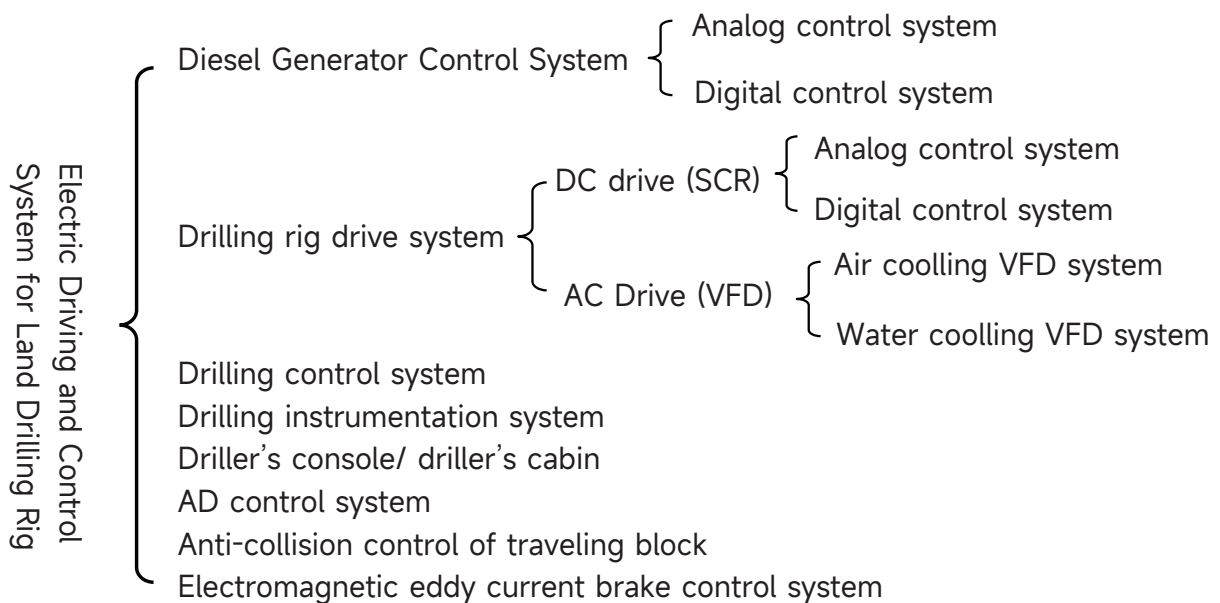

(Electric Control Room-DC)

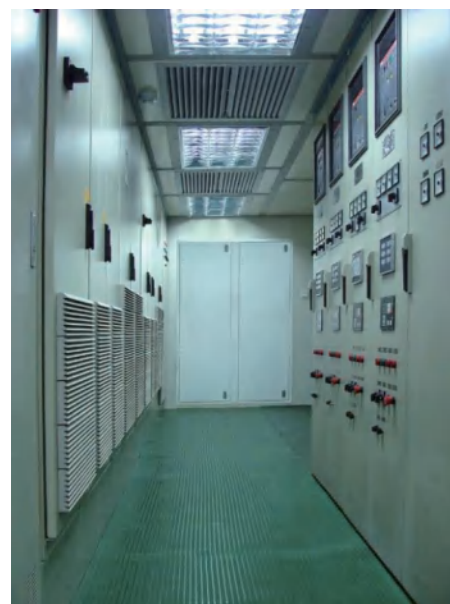

(Electric Control Room-VFD)

Main Functions: << <

- Precise control of diesel engine speed and generator voltage.
- Multiple generators running in parallel.
- Protection of generator (under-voltage, over-voltage, over-current, short circuit, under-frequency, over-frequency and reverse power).
- Power limit (to prevent GEN overload).
- Motor drive and control of (DW, RT, MP, TD).
- Power distribution of drilling rig auxiliary equipment.
- Drilling control.
- Integrated drilling instrument.
- Electronic driller's console/chair.
- Local control of mud pump.
- Auto drilling control.
- Anti-collision of traveling block.
- Energy consumption braking of DW.
- Anti-skid protection of mud pump pulley.
- Electromagnetic eddy current brake control.



(Local Console of Mud Pump)



(Electronic Driller Chair)



(Electric Control Room)

POWER PRODUCTS

SHORE POWER SYSTEM

The shore power system is mainly used to convert the port's shore based power into the power supply that suitable for various ship power systems. The shore power system includes two types: mobile shore power system and port shore power system. The system include converter for voltage/frequency conversion, voltage/frequency stabilization devices, shore power socket boxes, ship substations, high-voltage cable drums, and shore power management systems.

Our shore power products are specially designed for harsh environments such as high temperature, high humidity, high corrosiveness, and heavy load impact on ships and docks. The frequency converter and reactive power compensation device use the well-known brands, which meet industry application requirements; All circuit boards are treated with coating curing; The sine filter and output transformer are treated with overall vacuum impregnation insulation and high-temperature protective paint spraying, which have a high insulation level and protective ability; The product complies with relevant standards.

Mobile Shore Power System Parameters: > >>

- Input voltage: 10/6/0.38 kV(+10%,-15%) optional.
- Input frequency: 50Hz(+10%,-10%).
- Power capacity: 500~3500KVA (designed as required)
- Output voltage: 0.4/0.44/0.48/0.69/6.6 kV/60Hz/3P sine wave power (designed as required).
- Working mode: continuous working(ambient temperature < 50°C)
- Protection functions: phase loss, overvoltage, under voltage, over current, short circuit, over temperature, inverter or transformer over heating, etc.
- Cooling mode: forced air cooling.
- Outdoor installation, with protection level of IP54.

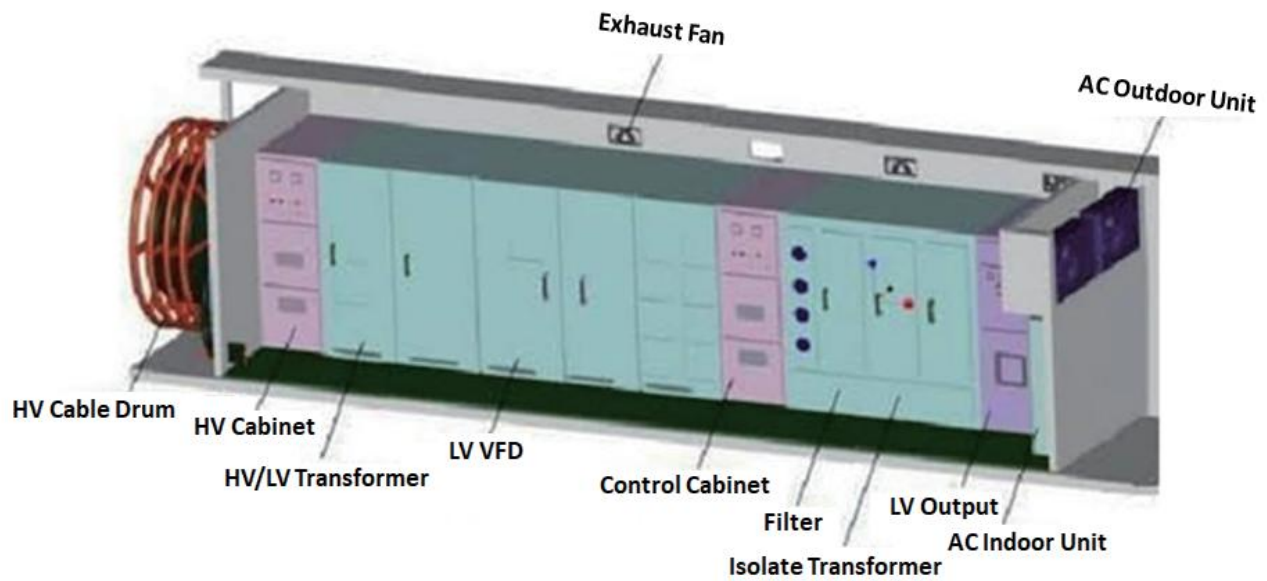

(Mobile Shore Power System)

Port Shore Power System Parameters: > >>

- Input voltage: 10KV(+10%,-15%)
- Input frequency: 50Hz(+10%,-10%)
- Power capacity: 3000~5000KVA (designed as required)
- Output voltage: 6.60kV/60Hz/3P sine wave power supply (designed as required)
- Working mode: continuous working(ambient temperature < 50°C)
- Cooling mode: forced air cooling
- Protection functions: phase loss, over voltage, under voltage, over current, short circuit, over temperature, inverter and transformer over heating, etc.

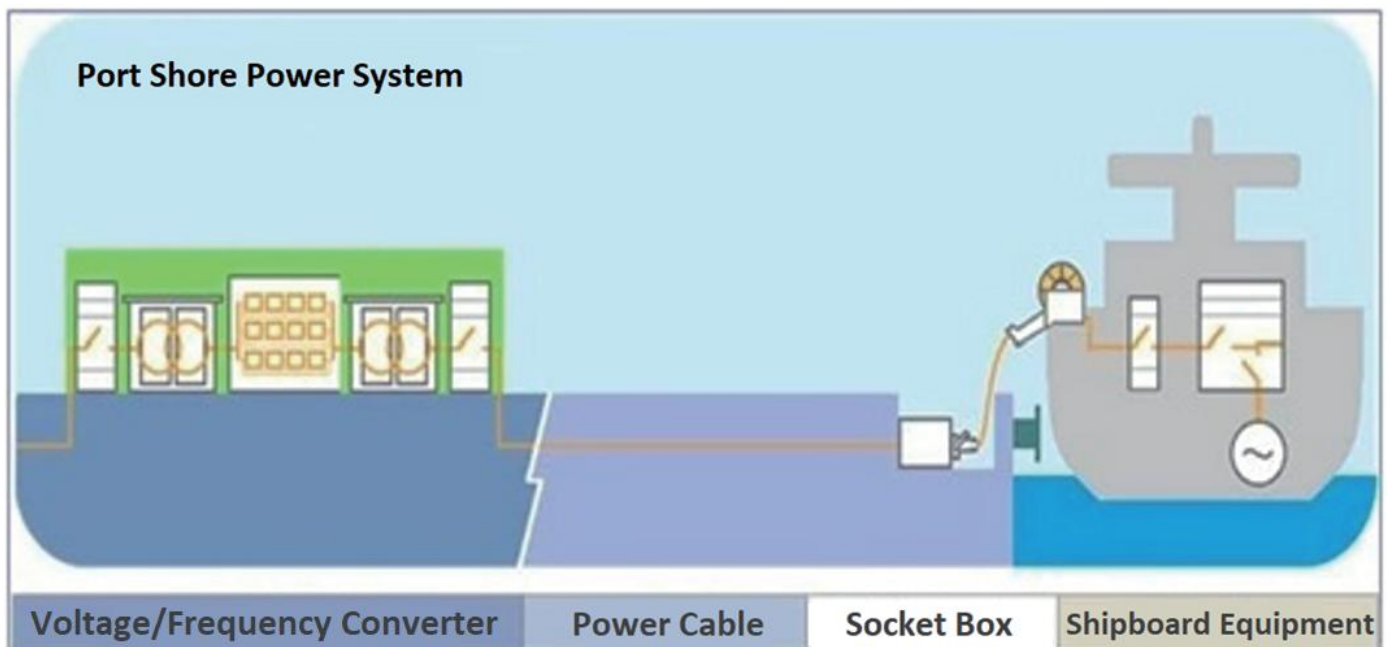

POWER QUALITY MANAGEMENT

HHCT Power Quality Product Series - SVG Introduction > >>

HHCT offers a variety of reactive power compensation and harmonic suppression product solutions, mainly applied in multiple fields such as oil drilling rigs, metallurgy, chemical industry, and ports. The SVG device, when connected to the power grid, acts as a variable reactive current source, whose reactive current can quickly follow the changes of load reactive current, automatically compensating the system's required reactive power.

The main functions are as follows:

- Enhance the stability of power transmission lines
- Maintain the voltage at the receiving end and strengthen the stability of system voltage
- Compensate for system reactive power and improve power factor
- Dynamic compensation of harmonics to improve power quality
- Suppress voltage fluctuations and flicker
- Mitigate three-phase imbalance

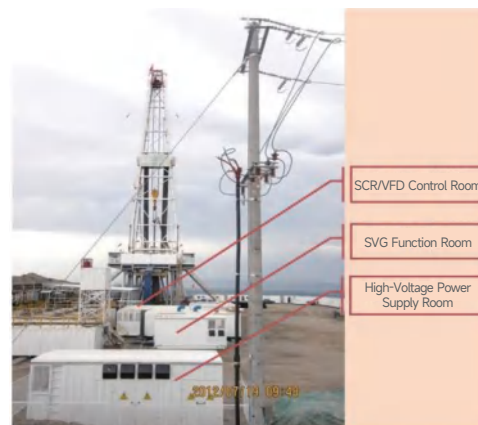

功率模块

Key features of the SVG power module include:

- Modular design, allowing individual or simultaneous compensation of reactive power and harmonics by each module unit;
- Strong capability to control voltage fluctuations and flicker;
- Utilizes PWM interleaving technology, resulting in low self-harmonic content;
- Designed for a service life of up to 20 years;
- High system efficiency with low self-consumption;
- Convenient for installation and testing, requiring minimal maintenance.

Control Unit

- Core control based on dual DSP chips;
- Master-slave control with data information acquisition and processing;
- Interleaved PWM wave control;

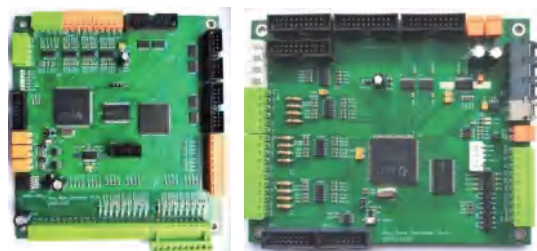

Core Components

- IGBT modules utilize leading brand products such as Infineon and Fuji Electric;



HM Interface

- Graphical user interface display;
- Monitoring and diagnostics of operating status;



SVG Product Technical Specifications					
Rated Voltage: 400VAC	SVG-500/0.4	SVG-750/0.4	SVG-1000/0.4	SVG-1500/0.4	SVG-2000/0.4
Rated Voltage/Current	400VAC/721A	400VAC/1082A	400VAC/1443A	400VAC/2165A	400VAC/2886A
Rated Voltage: 600VAC	SVG-600/0.6	SVG-900/0.6	SVG-1200/0.6	SVG-1800/0.6	SVG-2400/0.6
Rated Voltage/Current	600VAC/577A	600VAC/866A	600VAC/1155A	600VAC/1732A	600VAC/2309A
Cabinet Dimensions (WxDxH, mm)	600×800×2200	900×800×2200	1200×800×2200	1800×800×2200	2400×800×2200
Harmonic Compensation	When the reactive power compensation is less than the rated current, harmonic compensation for the 3rd, 5th, 7th, and 11th harmonics can be selected, with the harmonic compensation current not exceeding 30% of the rated value				
Switching Frequency	Single module at 4kHz, and multiple modules can be phase interleaved				
Number of Power Units	2	3	4	6	8
Wiring Method	Three-phase three-wire line input (standard product)				
Overload	Overload: 1.2 times the rated current, 5 minutes				
Cooling Method	Forced air cooling				
Reactive Power Adjustment Range	From capacitive rated reactive power to inductive rated reactive power				
Control Method	1.Constant reactive power 2. Constant power factor 3. Proportional compensation according to reactive current 4. Reactive and harmonic compensation				
Protection Features	Grid overvoltage, undervoltage, phase loss, bus overvoltage, undervoltage, overcurrent, current limiting, temperature high				
Response Delay	Fast response time less than 0.5ms, full compensation time less than 5ms				
Operating Temperature	35°C (derate use above 35°C)				
Operating Altitude	2000 meters, derate use at higher altitudes				
Relative Humidity	RH<95%, no condensation				
Communication Methods	Modbus-RTU, Modbus-TCP, other communication methods are optional				

SVG Product Applications:



SVG Complete Equipment

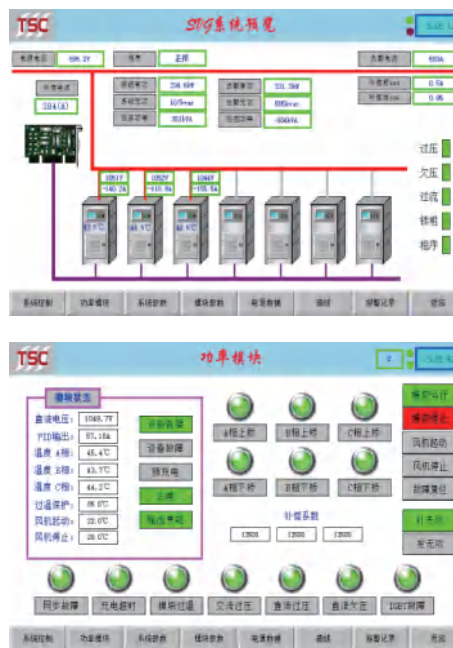

Typical HMI

SPECIAL EQUIPMENT CONTROL AND DRIVE SYSTEM

CONTROL SYSTEM OF SHIP LARGE-SCALE THIN-PLATE SECTION TURNING OVER DEVICE

The turning over device is used for turning-over of ship large-scale thin-plate section. the rated working weight of the turning-over device is 180t, and the maximum size of the section is 36m×24m×4.8m. the turning device control system integrates the device lifting, turning and trolley control to complete the whole process of turning over.

The system contains: > >>

- Locking trolley drive and control system
- Local control box
- Power distribution box
- Center control console
- Remote control device
- CCTV system
- External control interface

System function: > >>

- Centralized/independent positioning and locking of 10 trolleys
- Trolleys remote control
- Operation monitoring by video camera
- Three-dimensional and six-direction motion control of lug plate locking mechanism
- Segmented lug locking
- Device lifting control
- Device turnover control





华商能源科技股份有限公司

CM Energy Tech Co., Ltd.

Add: 5th Floor, Cruise R&D Center, No.866-1 Shanghai Road, Haimen District, Nantong City,
Jiangsu Province, China, 226100

Contact Person:

Mr. WU: (+86) 13186007561

Mr. JIN: (+86) 13991141739

Email: sales.cn@cm-energy.com